

SUPER SIVTEK®



THE ROBUST HIGH VIBRATION SIFTER PRODUCING 3X VIBRATIONS.

The Super Sivtek Separator is a high-powered vibrating sieving machine that can produce up to three times more vibration than conventional sieving machines. Each round of the Super Sivtek delivers higher throughput of ultra-fine mesh, thanks to its wide range of high-powered functionalities.

It is capable of precisely separating up to five levels of particle gradation in one operation due to its finesse and accuracy. Super Sivtek is an ideal industrial sieving machine because of its compact size and high-capacity vibrations, which can help you maximize your productivity.

With its adjustable motor weights and seamless rotating angles, the sieving machine can generate powerful vibrations. A meticulously designed high intensity vibrating screen separator helps the sieving machines handle even the toughest sieving jobs with ease. Besides the strong bearing housing, Super Sivtek also has motors mounted on the side that work according to the Bet and Pully principle.

BENEFITS



HIGHER THROUGHPUT

Unlike conventional vibrating screeners, Super Sivtek can produce a significantly higher throughput due to its heavy-duty motion generator.



OPTIMUM CAPACITY

The Super SIVTEK high-capacity separator provides up to five levels of gradation in just one operation for precise particle size distribution.



COST-EFFICIENT

You will require fewer vibrating separation systems because of Super SIVTEK's high throughput.

KEY COMPONENTS



01
OUTLET
Allows easy discharge of the oversize and undersize material.

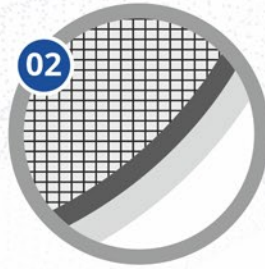

02
RUBBER GASKET
Rubber gasket is wrapped around the screen ring to achieve zero gap design and to avoid metal friction.



03
SCREEN RING
A woven mesh screen ring placed in the virbo sifter to separate different sized particles.

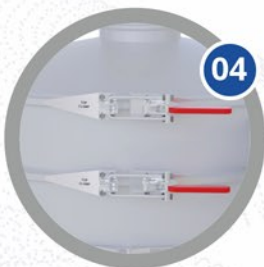

04
TOGGLE CLAMP
Clutch the screen ring between both the upper & lower deck of the super vibro Separator.



05
SPRINGS
Set of springs to support the machine vibration.



06
STANDARD MOTOR
A standard motor is used with a belt & pulley mechanism to generate the vibrations.

FEATURES

▶ MADE WITH HIGH-QUALITY PRODUCTS

Super Sivtek separators are made from the highest quality material and are approved by the US-FDA and cGMP.

▶ MULTIPLE SCREEN RING OPTIONS

The machine comes with multiple screen ring options available depending upon the application and requirement of the customer.

▶ MULTIDECK SEPARATION

Easily increase or decrease number of deck to achieve gradation.

▶ LEAD ANGLE SETTINGS

Change the lead angle settings as per the desired vibrating motion.

▶ DRY & WET TYPE MATERIAL

Get high quality separation with both dry and wet materials.

▶ GENERATES HIGH-CAPACITY VIBRATIONS

The Super Sivtek Separator can generate 3 times more vibrations than an ordinary separator, which helps to screen fine mesh up to 500#.

TYPES OF SCREEN RING SUPPORTED

▶ SANDWICH SCREEN RING

Sandwich screen ring comes with bolting system arrangement which will enable the mesh frame to reuse & change mesh cloth in lesser time.



▶ US-FDA COMPLIANT RING

US-FDA Compliant ring used for screening hygienic products delivers better mesh tension & better efficiency.



▶ STANDARD SCREEN RING

SIVTEK screen ring comes with smooth surface finish. It can be customized as per the requirement and the application.



MATERIAL HANDLING

► SCREW CONVEYOR



► CUSTOMIZED HOPPER



► POWDER TRANSFER SYSTEM



► BUCKET ELEVATOR



CAPACITY ENHANCERS

► ULTRASONIC SIVTEK

The Ultrasonic Sivtek enable you to sieve your powders on fine meshes with more accuracy than ever before. This improves the quality of your final products as well as their value.



► MESH DEBLINDING KIT

Mesh Deblinding Kit is an excellent anti-blinding device which primarily works on elastomeric balls that can conveniently eradicate any fine particle. Due to the vibrations of the machine, the balls start bouncing and prevent the screening material from getting clogged in and around the sieve.



► CLEAN IN PLACE

Clean in place is a method of automated cleaning the interior surface of the vibro screen and filters and associated fittings. The CIP is used for cleaning, unclogging, de lumping of the mesh screen or the related fittings.



► ROTARY BRUSH

Rotary brush system for vibro screen separators consists of a brush system and mobile chassis. It operates independently with the separator at low rpm. Lumps are broken apart by horizontal scraping motions and vertical crushing motions between the brush and screen.



INDUSTRIES & APPLICATIONS WE SERVE



GLASS & CERAMICS

- Silica
- Alumina
- Glass Powder
- ALC Powder



FOOD & BEVERAGE

- Corn Starch
- Spices / Flour
- Grains / Seeds
- Baking Soda



PHARMA

- Pharma powder
- Syrup
- Homeopathy
- Herbal / Ayurvedic



INKS & PAINTS

- Liquid Paint
- Powder Paint
- Grinding Media
- Printing Ink



AGRICULTURE & FERTILIZER

- Cattle Feed
- Tobacco
- Urea
- Npk



FMCG

- Detergent Powder
- Soap Noodles
- Talcum Powder
- Tooth Powder



CEMENT & SAND

- Quality Check
- AAC Blocks
- Garnet Sand
- Silica Sand



CHEMICAL & PIGMENT

- Epoxy / MBS Resin
- Pigments
- Activated Carbon
- Charcoal



MINERAL & METAL

- Metal Powder
- China Clay
- Calcium Carbonate
- Quartz

Many More...

SCREEN SURFACE IN DIFFERENT WEIGHT PHASES

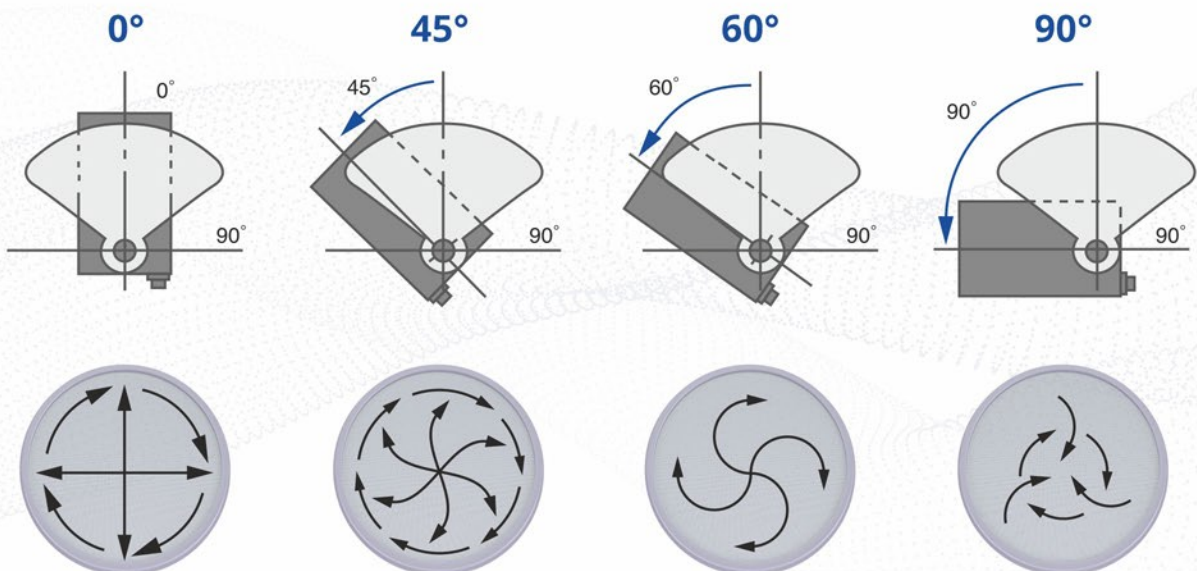

AFTER SALES SERVICES

24 x 7 CUSTOMER SUPPORT

Galaxy sivtek is committed to provide you 24x7 customer support on your sieving and filtration challenges. We are bound to assist you before and after purchase of our sieving and filtering solutions. We also offer genuine after market spares to ensure that your production lines are always running. Get in touch with our team at any time.

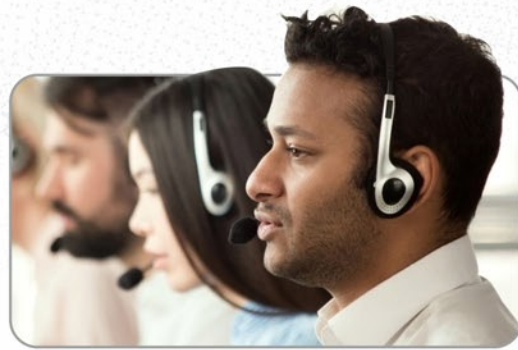

INHOUSE & ON SITE TRIAL FACILITY

Galaxy Sivtek conduct on site trial for processing industries, so that they can make appropriate decision to choose from the wide range of our Sivtek sifters and filters. Till date, we have successfully conducted more than 25k+ trials for 12+ industries ranging from food & beverage to the chemical industry, pharmaceutical to mineral & metal industry.

MACHINE HEALTH CHECKUP

We work as your sieving & filtering solution partner! Our highly skilled & trained experts are at your service. We at Galaxy Sivtek help our clients in identifying how their machines are performing in the processing line, by conducting a machine health check-up. It will help them to analyse and take appropriate decisions.



TECHNICAL TRAINING

Training programs are conducted by Galaxy Sivtek to educate every technician or operator at your premises. In house & on site training program helps your operator to understand that how to operate, service & maintain the sieving & filtration equipment. Galaxy Sivtek also train them on how to detect & prevent physical hazards that may effect the sieving process.

COMMITTED GLOBALLY



SIEVING & FILTERING Solutions Galaxy Wide

 Plot No. 02, Siddhi Industrial Infrastructure Park, Behind MGVC Substation,
Waghodia - 391 760, Dist : Vadodara, Gujarat.

 inq@galaxysivtek.com  www.galaxysivtek.com

 +91 96876 99690

